

ADJUSTMENT

1. PREPARE VEHICLE FOR HEADLIGHT AIMING ADJUSTMENT

- (a) Prepare the vehicle:
- Ensure that there is no damage or deformation of the body around the headlights.
 - Fill the fuel tank.
 - Fill the oil to the specified level.
 - Fill the coolant to the specified level.
 - Inflate the tires to the appropriate pressure.
 - Place the spare tire, tools and jack in their original positions.
 - Unload the trunk.
 - Sit a person of average weight (68 kg, 150 lb) in the driver seat.

2. PREPARE FOR HEADLIGHT AIMING (for Using a Tester)

- (a) Prepare the vehicle for headlight aim check.
 (b) Adjust the headlight in accordance with headlight tester instructions.

3. PREPARE FOR HEADLIGHT AIMING (for Using a Screen)

- (a) Prepare the vehicle in accordance with the following conditions:
- Place the vehicle in a location that is dark enough to clearly observe the cutoff line. The cutoff line is a distinct line, below which light from the headlights can be observed and above which it cannot.
 - Place the vehicle at a 90° angle to the wall.
 - Keep a 7.62 m (25 ft) distance between the center of the headlight bulb and the wall.
 - Place the vehicle on a level surface.
 - Bounce the vehicle up and down to settle the suspension.

NOTICE:

A distance of 7.62 m (25 ft) between the vehicle (the center of the headlight bulb) and the wall is necessary for proper aim adjustment. If unable to secure a distance of 7.62 m (25 ft), set a distance of exactly 3 m (9.84 ft) to check and adjust the headlight aim. (Since the target zone changes depending on the distance, follow the instructions shown in the illustration.)

- (b) Prepare a piece of thick white paper (approximately 2 m (6.6 ft) high x 4 m (13.1 ft) wide) to use as a screen.
 (c) Draw a vertical line down the center of the screen (V line).

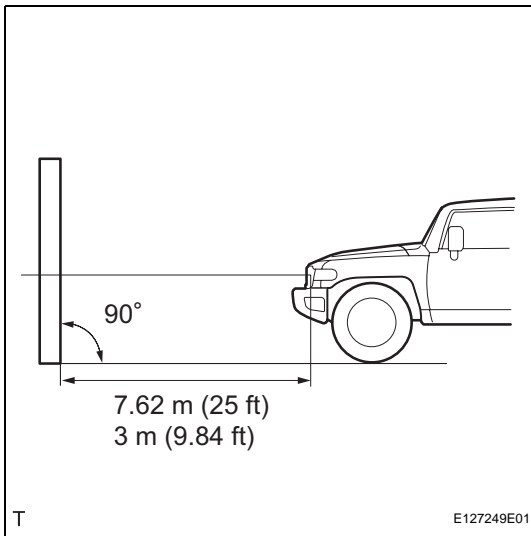

T

E127249E01

LI

(d) Set the screen, as shown in the illustration.

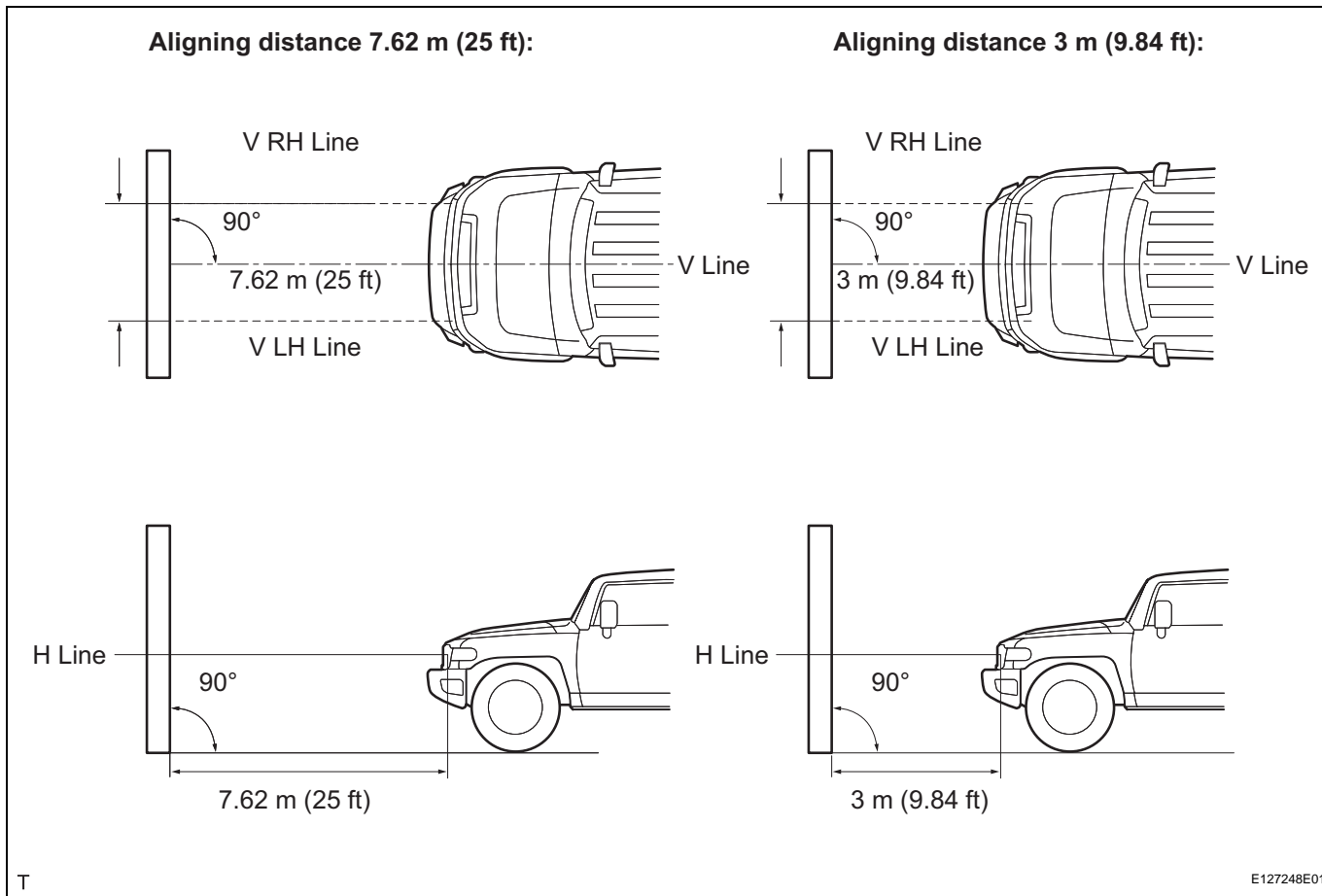

HINT:

- Stand the screen perpendicular to the ground.
- Align the V line on the screen with the center of the vehicle.

(e) Draw base lines (H line, V LH and V RH lines) on the screen, as shown in the illustration.

HINT:

- The base lines differ for "low-beam inspection" and "high-beam inspection".
- Mark the headlight bulb center marks on the screen. If the center mark cannot be observed on the headlight, use the center of the headlight bulb.

(1) H Line (Headlight height):

Draw a horizontal line across the screen so that it passes through the center marks. The H line should be at the same height as the headlight bulb center marks of the low-beam headlights.

(2) V LH Line and V RH Line (Center mark positions of left-hand (LH) and right-hand (RH) headlights):

Draw two vertical lines so that they intersect the H line at each center mark (aligned with the center of the low-beam headlight bulbs).

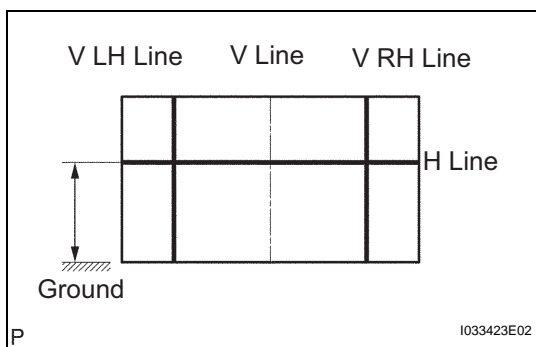

4. INSPECT HEADLIGHT AIMING

- (a) Cover the headlight on the opposite side or disconnect its connector, to prevent light from the headlight not being inspected from affecting the headlight aiming inspection.

NOTICE:

Do not keep the headlight covered for more than 3 minutes. The headlight lens is made of synthetic resin, and may easily melt or be damaged due to heat.

- (b) Start the engine.

NOTICE:

Engine rpm must be 1,500 or more.

- (c) Turn on the headlight and make sure that the cutoff line falls within the specified area, as shown in the illustration.

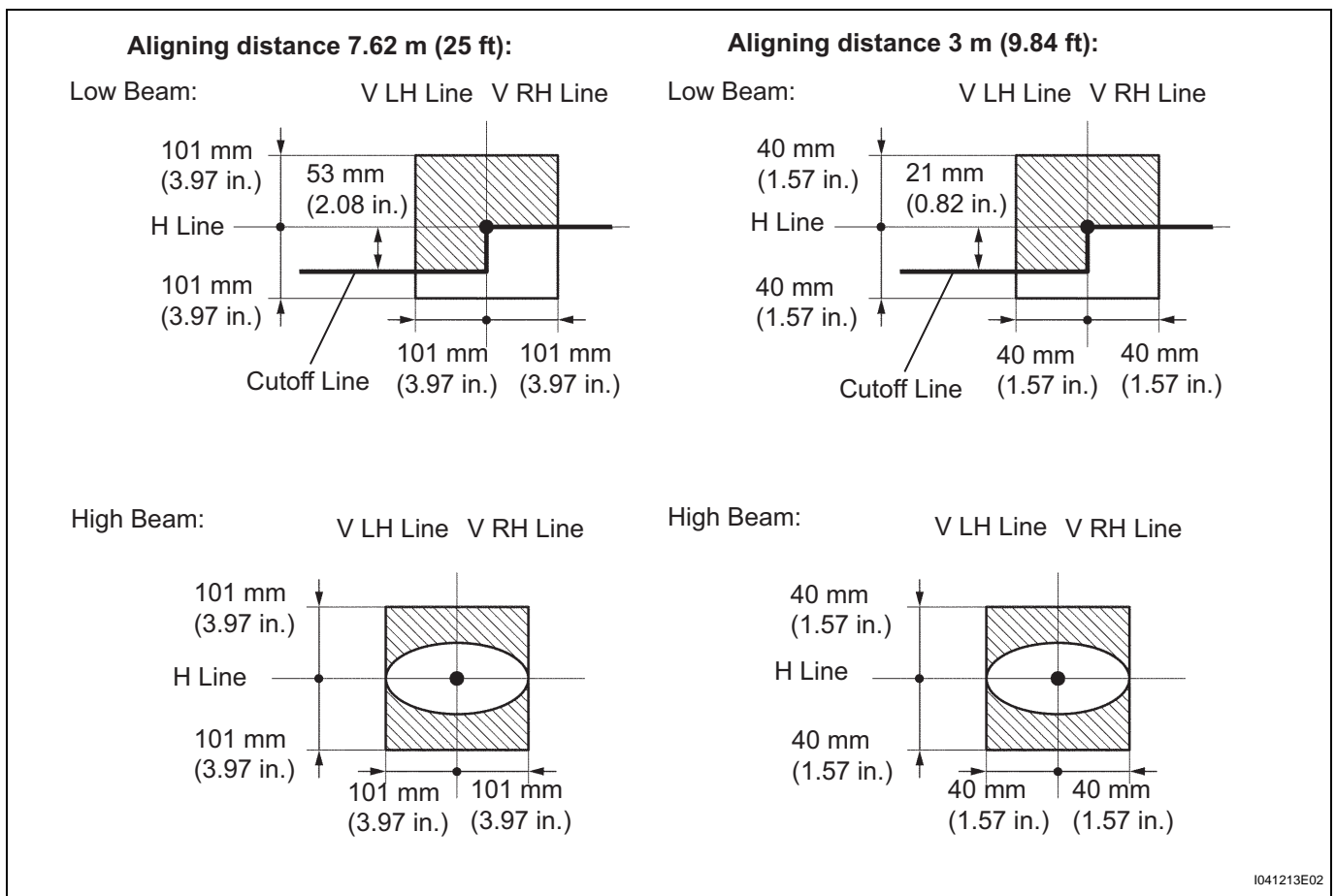

HINT:

- Since the low-beam light and the high-beam light are a unit, if the aim on one is correct, the other should also be correct. However, check both beams just to make sure.
- Alignment distance is 7.62 m (25 ft): The cutoff line is 101 mm (3.97 in.) above and below the H line as well as to the left and right of the V line with low-beam (SAE J599).

- Alignment distance is 3 m (9.84 ft):
The cutoff line is 40 mm (1.57 in.) above and below the H line as well as to the left and right of the V line with low-beam (SAE J599).
- Alignment distance is 7.62 m (25 ft):
The cutoff line is 101 mm (3.97 in.) above and below the H line as well as to the left and right of the V line with high-beam (SAE J599).
- Alignment distance is 3 m (9.84 ft):
The cutoff line is 40 mm (1.57 in.) above and below the H line as well as to the left and right of the V line with high-beam (SAE J599).
- Alignment distance is 7.62 m (25 ft):
The cutoff line is 53 mm (2.08 in.) below the H line with low-beam.
- Alignment distance is 3 m (9.84 ft):
The cutoff line is 21 mm (0.82 in.) below the H line with low-beam.

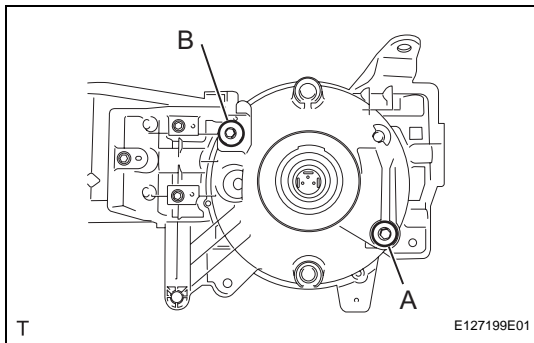

5. ADJUST HEADLIGHT AIMING

- (a) Adjust the aiming vertically.

Adjust the headlight aim to within the specified range by turning aiming screw A with a screwdriver.

NOTICE:

The final turn of the aiming screw should be made in the clockwise direction. If the screw is tightened excessively, loosen it and then retighten it, so that the final turn of the screw is in the clockwise direction.

- (b) Perform low-beam aim adjustment.

HINT:

The headlight aim moves down when the aiming screw is turned clockwise, and moves up when the aiming screw is turned counterclockwise.

- (c) Adjust the aim horizontally.

Adjust the headlight aim to within the specified range by turning aiming screw B with a screwdriver.

NOTICE:

The final turn of the aiming screw should be made in the clockwise direction. If the screw is tightened excessively, loosen it and then retighten it, so that the final turn of the screw is in the clockwise direction.

REASSEMBLY

1. INSTALL FRONT TURN SIGNAL LIGHT BULB

- (a) Install the front turn signal light bulb into the light socket.
- (b) Turn the front turn signal light socket and bulb, in the direction indicated by the arrow in the illustration, to install them.

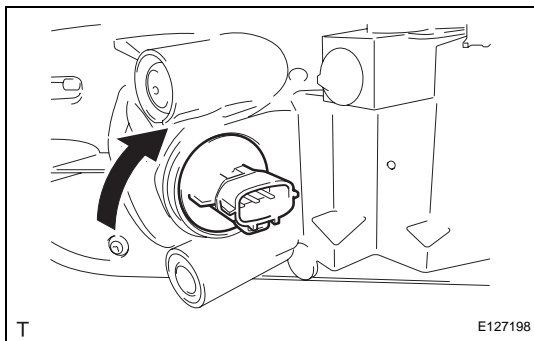

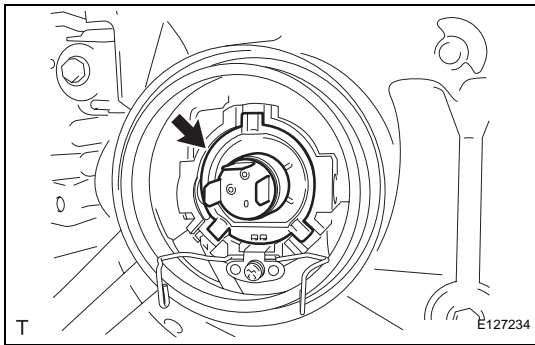

2. INSTALL HEADLIGHT, NO. 1 BULB

(a) Install the headlight, No. 1 bulb.

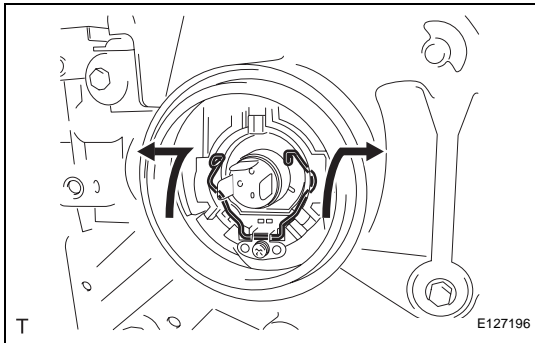

(b) Lock the set spring by moving it in the directions indicated by the arrows in the illustration.

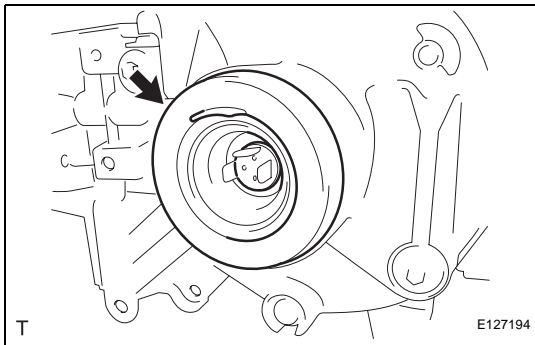

(c) Install the socket cover.

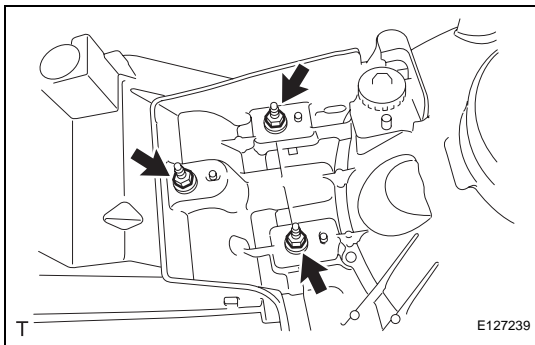

3. INSTALL HEADLIGHT ASSEMBLY

(a) Install the headlight with the 3 nuts.

Torque: 5.4 N*m (55 kgf*cm, 48 in.*lbf)